

ACCESS COVER (CLEAR OPENINGS)		
LENGTH (mm)	WIDTH (mm)	TYPE
750	600	5 TONNE

FABRICATION SPECIFICATIONS			
ITEM	INDEX	DEPTH/DIAMETER (mm)	CLOCK FACE POSITION
Tank depth	A	2000	
Tank $\phi$	B	1000	
Inlet	C1	110	
Inlet	C2		
Inlet	C3		
Inlet	C4		
Discharge	D	500	63/90
Cable duct			110
Vent			

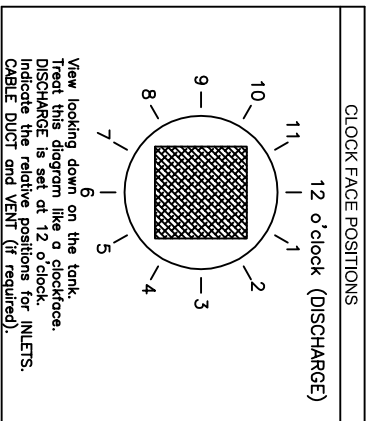

PLEASE NOTE THAT THIS DOCUMENT MUST BE READ IN CONJUNCTION WITH THE INSTALLATION & OPERATING GUIDELINES. DRAWING NOT TO SCALE

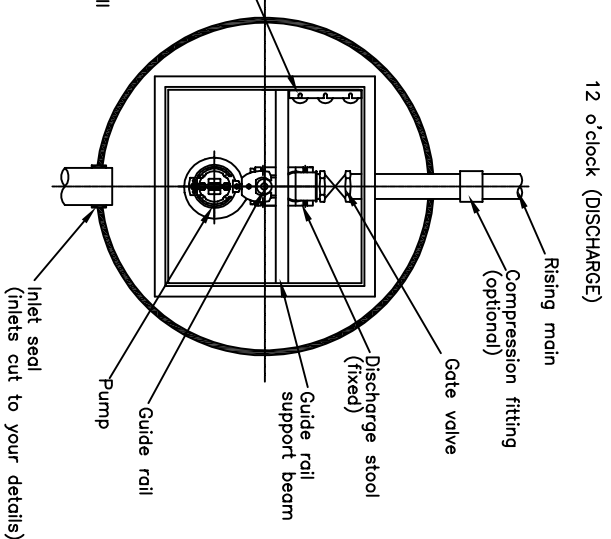
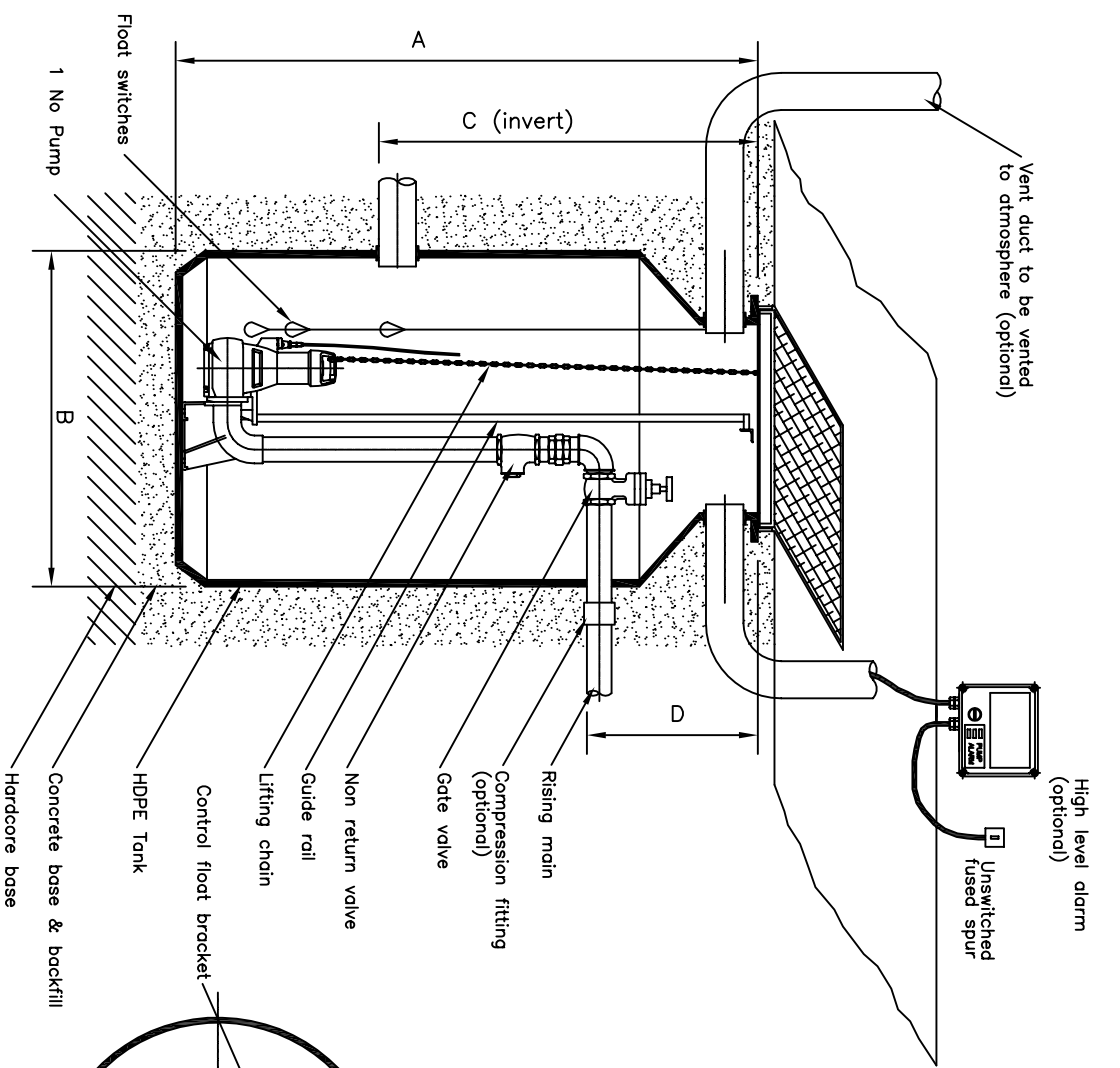

Comments

Please note that the inlet can be supplied loose and drilled on site.

Customer.	
Project.	Drawing No.
Project address.	Date.
	Drawn by.
	Checked by.