

EVAK HIPPO SERIES

heavy duty submersible pumps for dirty water and sewage

Available in 230V single phase (Auto or Manual) and 400V three phase models, Hippo submersible pumps have been designed for arduous dirty water and sewage type applications. Guiderail option on Hippo 50/75/100. They feature recessed vortex impellers providing a 50mm dia. solids handling capability.

- Hippo 50 and 100 also available in 110/1/50
- Nominal 0.37 to 1.5kW (0.5 to 2HP)
- Thermal protector 1~ • Overload protector 3~
- Double mechanical seal (Ca/Ce + Sic/Sic)
- Oil bath with oil seal
- Cast iron/Stainless steel construction
- Maximum operating temperature 40°C
- 10m H07RN-F cable as standard

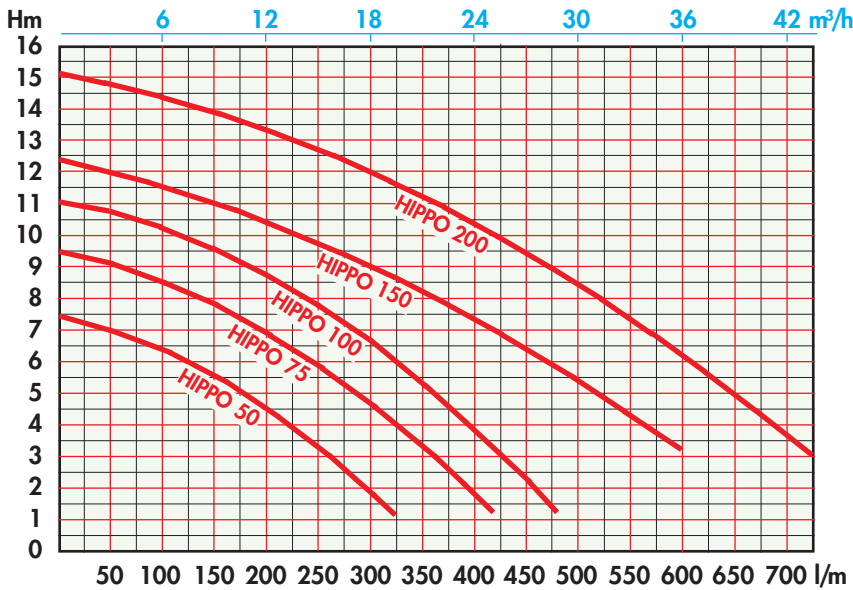
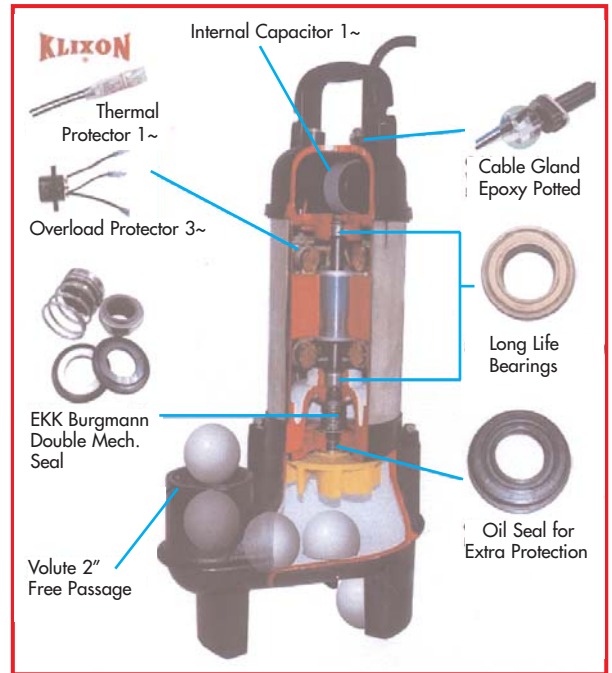

Hippo models also available in horizontal discharge for guiderail applications

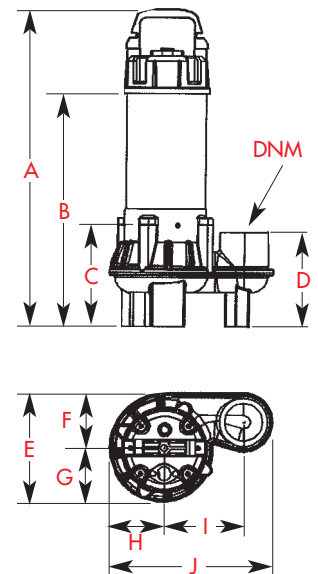

HIPPO Model	Nom. kW	Nom. HP	Nom. Amp		DNM	Dimensions mm										Weight Kg
			1~	3~		A	B	C	D	E	F	G	H	I	J	
50	0.37	0.5	3.4	1.1	2"	460	330	151	141	164	84	80	82	118	244	14
75	0.55	0.75	5.8	1.6	2"	482	352	151	141	164	84	80	82	118	244	16
100	0.75	1.0	6.5	2.2	2"	497	367	151	141	164	84	80	82	118	244	17
150	1.1	1.5	9.0	2.9	2"	506	376	151	143	186	98	88	93	135	271	25
200	1.5	2.0	12.0	3.4	2"	520	396	151	143	186	98	88	93	135	271	26

© Descriptions, technical data and features contained in this leaflet are not binding. We reserve the right to make any necessary modifications without prior notice.